

提升推拉门五金

产品型号: 502.011

产品性能符合: EN 13126-16:2008

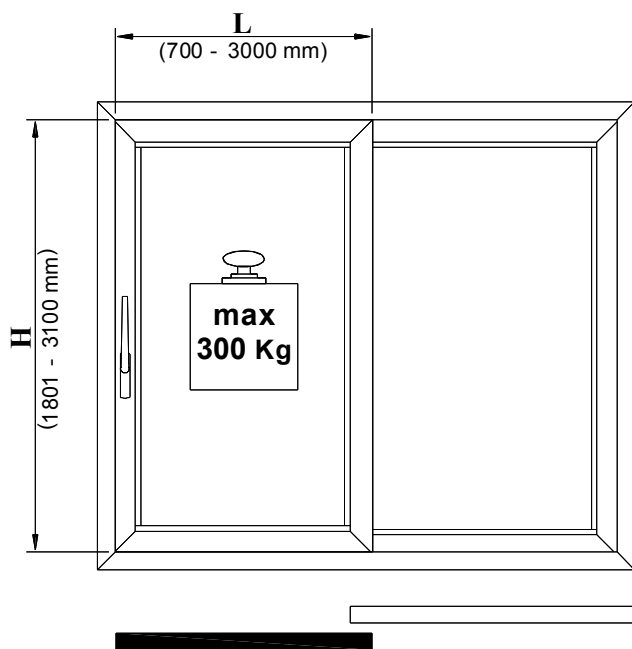
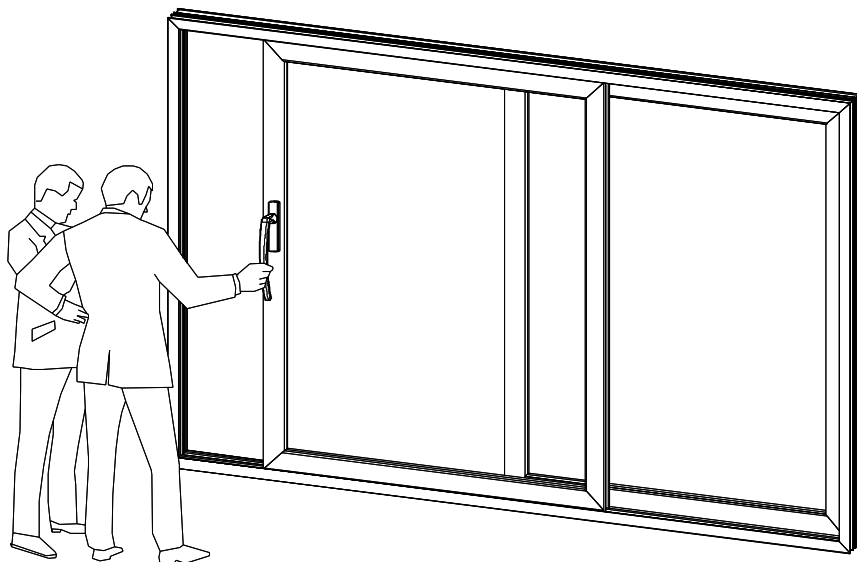

H = 门扇高

L = 门扇宽

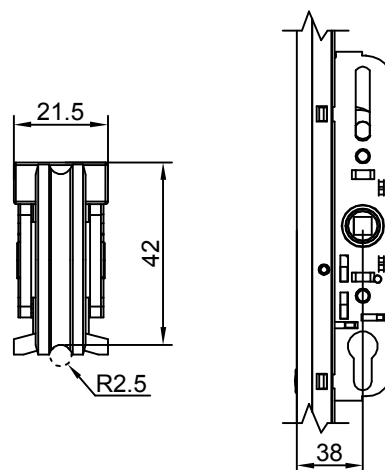
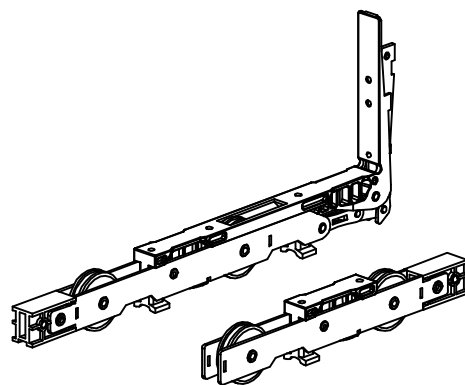

序号 NO.	编号 Number	产品名称 Description	数量 Quantity	说明 Notes
1	E-502.011	门把手	1 套	选配
2	F-502.011	锁芯	1 个	选配
3	502.011-20	传动器	1 支	标配, 高度2.4M
4	502.011-P	配件包	1 包	标配
5	A-502.011	提升推拉滑轮组件	1 根	标配
6	502.011-L	滑轮连杆	1 套	标配, 长度0.9M

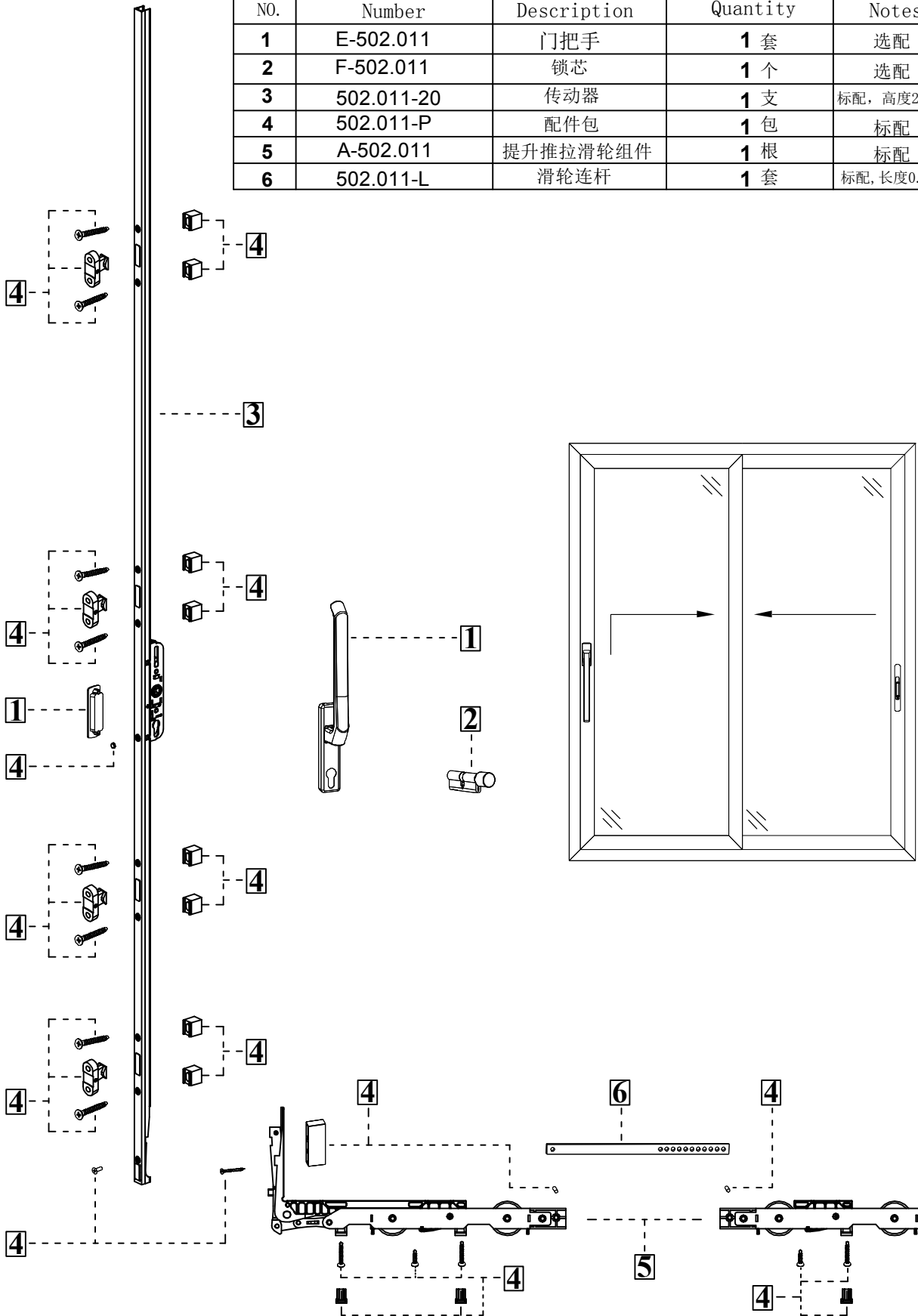

门扇高度 /mm	锁芯距离(HB)=38mm								
	传动器编号	HS	HA	H1	H2	H3			配件包编号
1800-2400	502.011-20-2400	2400	963	601	1202	1899	8	4	502.011-P-2400
2401-2800	502.011-20-2800	2800				2251			502.011-P-2800

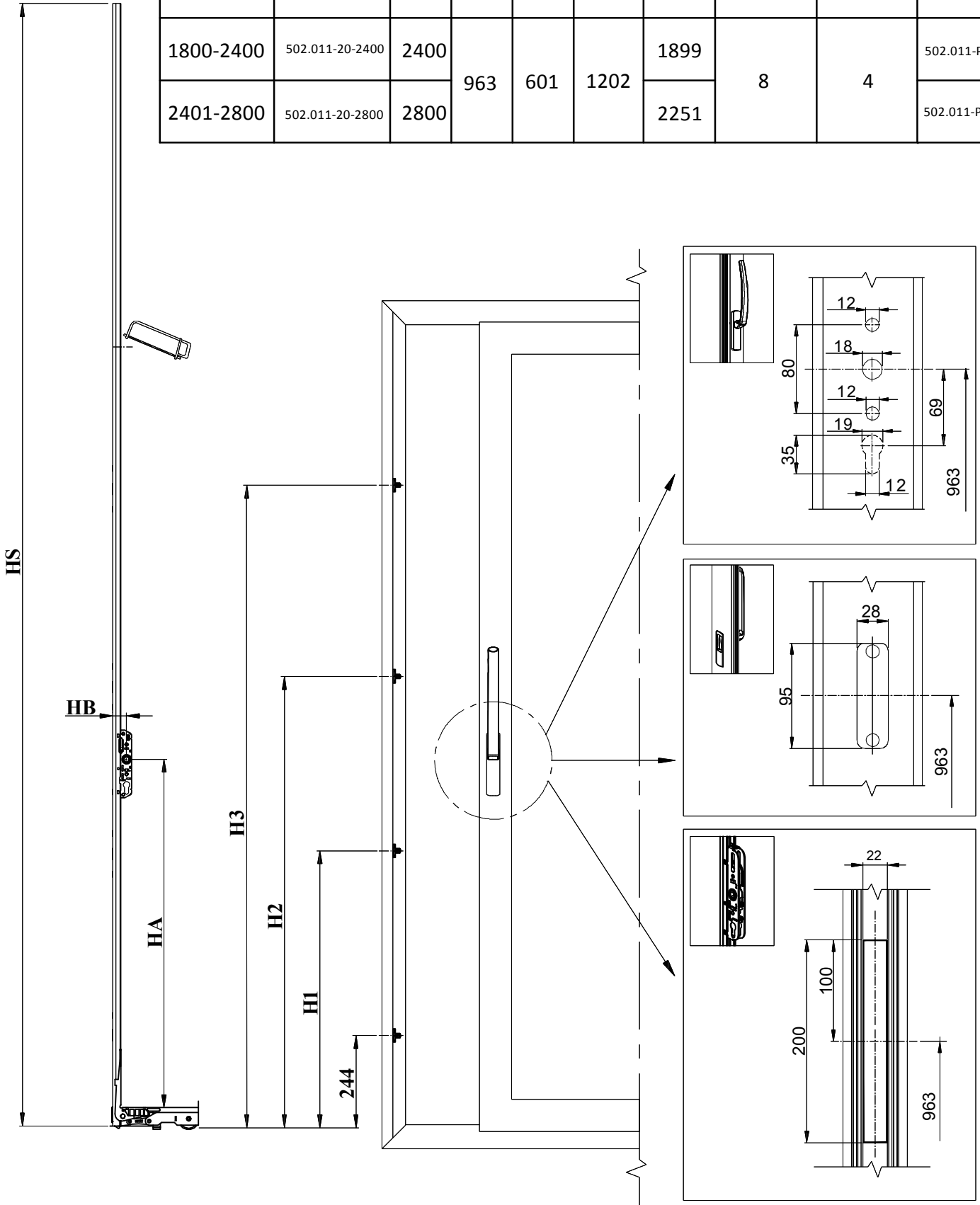

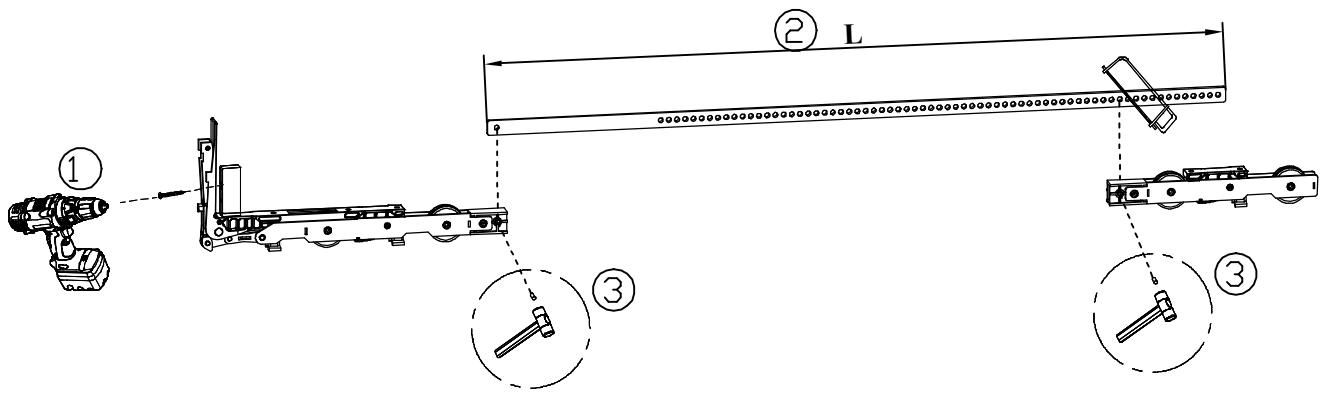

门扇宽度 /mm	连接杆长度L/mm	连接杆编号
700-1600	900	502.011-L-900
1601-2200	1500	502.011-L-1500
2201-3000	2200	502.011-L-2200

